

COMPONENTS • ENGINEERING • MANUFACTURING

NORTHCOMP[®]
exploring for people

NORTHCOMP
NORTHCOMP
NORTHCOMP

MANUFACTURING
MANUFACTURING
MANUFACTURING

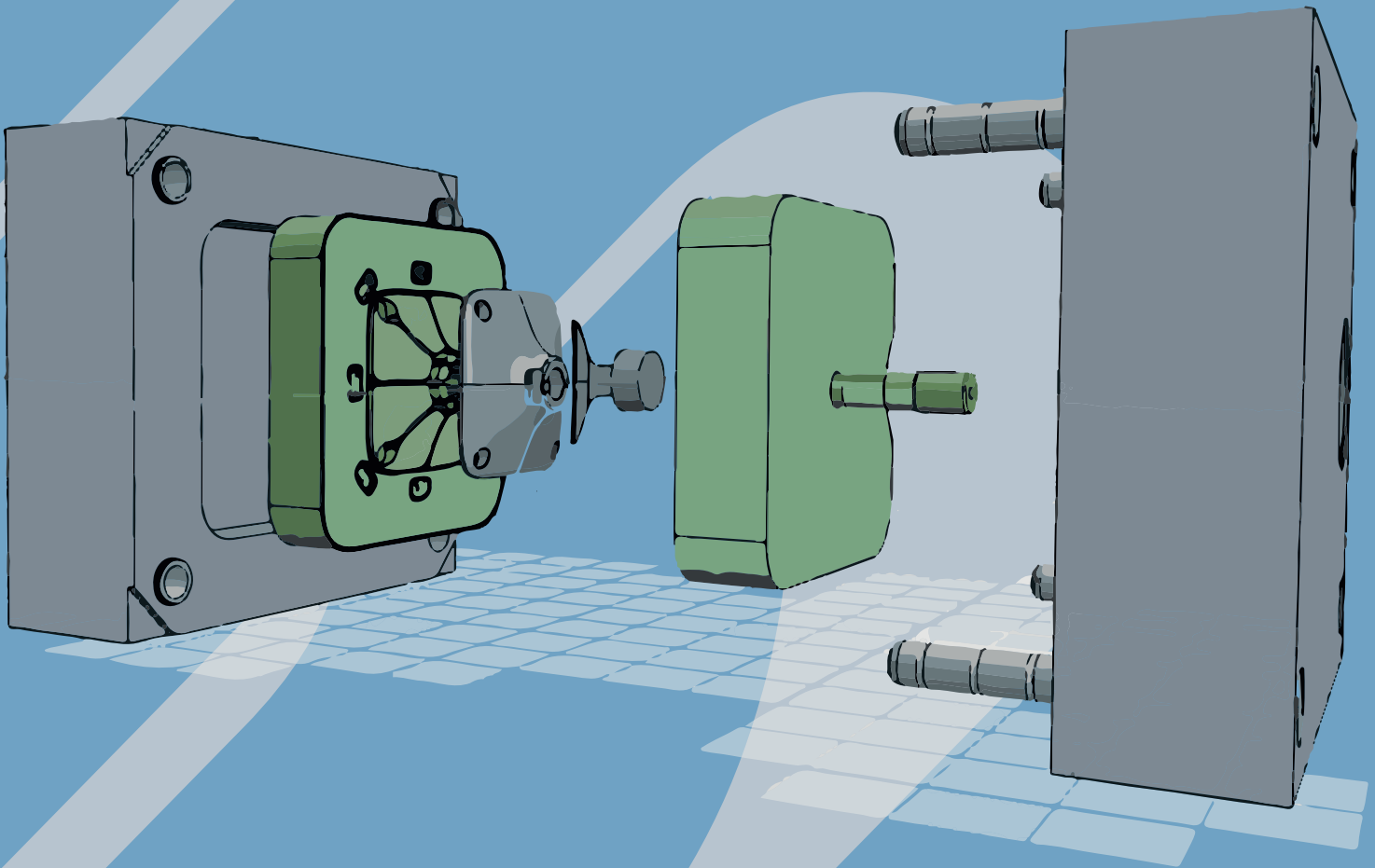

EMPOWERING PARTNERSHIPS
DRIVING INNOVATION

COMPONENTS



Discover our diverse selection of standard components to support your projects. We offer proven solutions to help you achieve your goals efficiently and successfully.

ENGINEERING

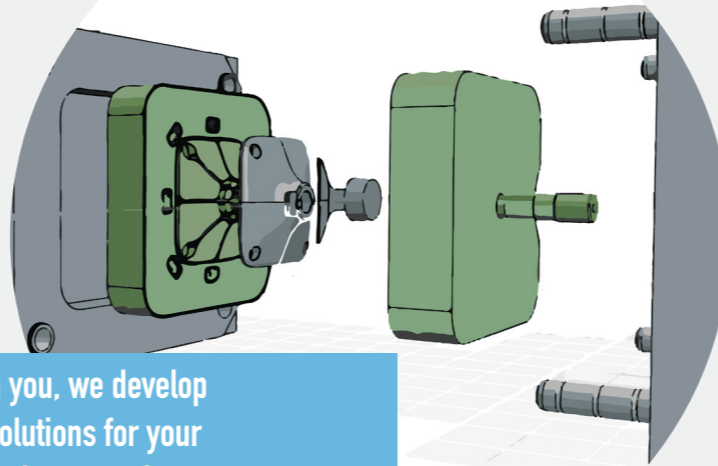

Together with you, we develop customized solutions for your individual requirements. Our experienced team is at your side to turn your ideas into reality.

MANUFACTURING



Our broad network of long-standing suppliers and service providers enables us to draw on a wide range of production depths to meet every requirement.

No limits.

Only possibilities.

 **100m²**
WEINMANN
MULTIFUNCTIONAL FIELD TEST

 **1986**
EXPERIENCE
FOR YEARS

4.003
PALLET
PLACES

MORE THAN **7.000**
 **PALLETS**
SHIPPED
PER YEAR



95% OF THE TIME
RECYCLING PAPER
IS USED



8.800 PACKAGES PER YEAR
100% CLIMATE-NEUTRAL

PAPER PRESS > 1 WASTE DISPOSAL
EVERY 4TH MONTH > LEADS TO

99,9%

LESS WASTE DISPOSAL PER YEAR

OVER 140
OWN TOOLS
IN MORE
THAN 5
COUNTRIES

 **9001 & 14001**

 **DESIGNED BY NORTHCOMP
& NETWORK OF DESIGNERS**

2 ENGINEERS
WITH **DECADES OF
EXPERIENCE**

 **MORE THAN
5.000**
ARTICLES
STORED IN
OUR CENTRAL
WAREHOUSE

5.600
QM² STORAGE
SPACE



LED LIGHTS
AT EVERY WORKSTATION



PAPER TAPE
INSTEAD OF PLASTIC TAPE

95% 
OF THE ELECTRICITY
REQUIREMENT
IS SELFSUFFICIENT



CHINA PARTNER SINCE 2016

4 N° / 1 KD TOOLS
100 EMPLOYEES
50 MACHINES 100-630T
15 WELDING MACHINES
ASSEMBLY PLACES
TEST LABORATORY
TOOLMAKING
FOCUS: STEEL PARTS
POWDER COATING



CHINA PARTNER SINCE 2018

38 KD GAS COLUMNS
400 EMPLOYEES
OWN PIPE PRODUCTION
45 MILLION \$ TURNOVER
3M PARTS/MONTH
38.000 M² AREA
TABLE-TOP GAS COLUMNS



LITAUEN PARTNER SINCE 2022

2 NORTHCOMP TOOLS
45 EMPLOYEES
300T / 750T / 1.000T
PART WEIGHT 0.5-3.0KG
10 POLISHING ROBOTS
8 CNC MACHINES
ISO 9001/14001
7000 M² SURFACE
ALUMINUM DIE CASTING
STEEL PARTS

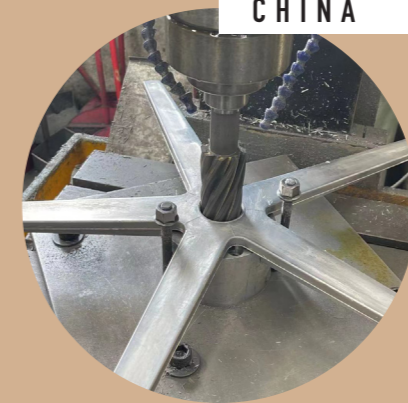

CHINA PARTNER SINCE 2002

17 N° / 7 KD TOOLS
50 EMPLOYEES
800T / 1.000T
PART WEIGHT 0.3-2.5KG
ISO 9001/14001
ALL TYPES ALUMINUM PARTS
SURFACES



POLEN PARTNER SINCE 2007

15 N° / 9 KD TOOLS
80 EMPLOYEES
400T / 850T / 1.000T
PART WEIGHT 0.5-5.0KG
8 POLISHING ROBOTS
TOOLMAKING FINISHING
ISO 9001/14001



CHINA PARTNER SINCE 1999

42 N° / 3 KD TOOLS
75 EMPLOYEES
48 MACHINES 25-300T
9 CU-SPRAYING MACHINES
CNC MACHINES
TOOL MAKING
TEST LABORATORY
ISO 9001
FOCUS: WHEELS & CASTORS
VARIOUS MATERIALS

GASLIFTS

ALUMINIUM

STEEL

NORTHCOMP®

exploring for people

OUR PARTNERS

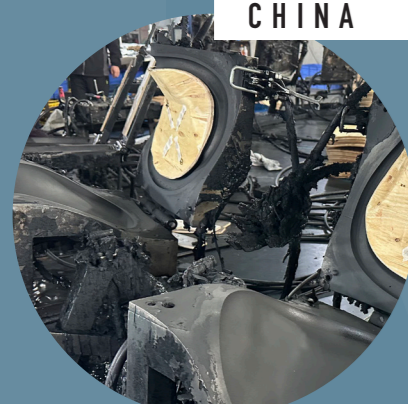

CHINA PARTNER SINCE 2018

18 NORTHCOMP TOOLS
80 EMPLOYEES
2 x FOAM CIRCLES/W
2 x FOAM CIRCLES/SW
TOOL MAKING
BRIGHT MOLDED FOAM
POLYURETHANE
SEATS, ARMRESTS, OTHER
2.000 M² AREA

FOAM

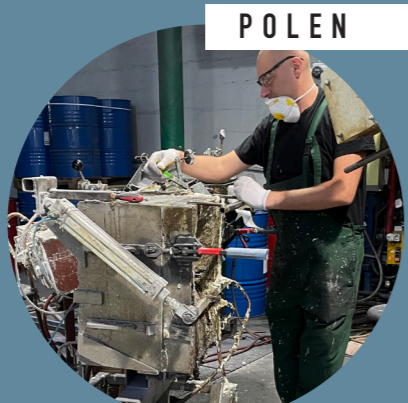

POLEN PARTNER SINCE 1995

15 N° / 10 KD TOOLS
25 EMPLOYEES
3 x HENNECKE HK 135
1 x TOP LINE 135
2 x CANNON A40
158K PARTS/YEAR
170KG MATERIAL/YEAR
1.800 M² AREA

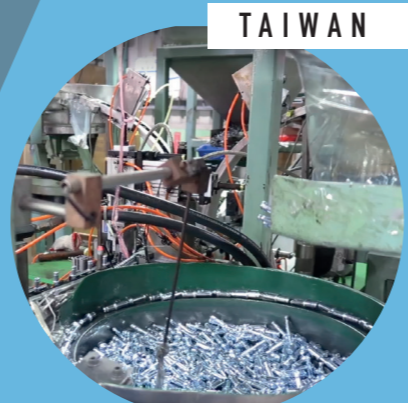

TAIWAN PARTNER SINCE 1998

7 N° / 3 KD TOOLS
160 EMPLOYEES
70 PCS. FROM 100T-800T
7 MIO. ROLLERS
50.000 ARMRESTS
13.000 FOOTRINGS/MONTH
IN-HOUSE TOOLMAKING
CONSTRUCTION
TEST LAB

PLASTIC incl. WHEELS & CASTORS



TAIWAN PARTNER SINCE 2015

15 N° / 1 KD TOOLS
53 EMPLOYEES
14 PCS. FROM 110T-1.000T
TOOL CONSTRUCTION
OWN MATERIAL MIX
ISO 9001/14001
BACKRESTS, ARMRESTS
SEATS, CHAIR BASES
OTHER PARTS

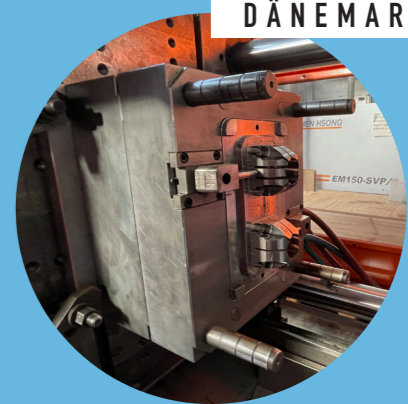

DÄNEMARK PARTNER SINCE 2020

5 NORTHCOMP TOOLS
15 EMPLOYEES 88T / 750T
PART WEIGHT 12GR-2.5KG
SIZE MAX. 910 x 350MM
OWN CONSTRUCTION
ALL TYPES PLASTIC PARTS
3.000 M² AREA

CHINA PARTNER SINCE 2024

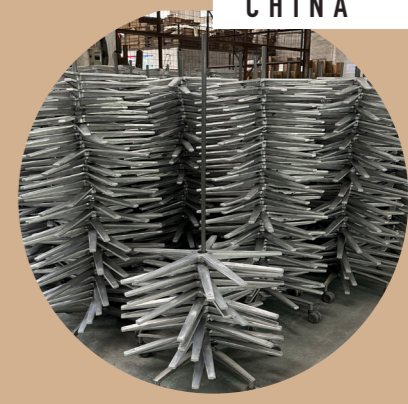

2 NORTHCOMP TOOLS
80 EMPLOYEES
ISO 9001
ROHS&REACH
IATF16949
A360/A380
EN AC44300
9.800 M² AREA

CHINA PARTNER SINCE 2002



19 N° / 6 KD TOOLS
50 EMPLOYEES
250T / 420T / 600T
PART WEIGHT 0.3-2.5KG
6 AXIS ROBOT

NORTHCOMP[®]
exploring for people

Northcomp GmbH
Heinrich-Schicht-Str. 9
42499 Hückeswagen

Germany
Phone: +49 (0) 2192 9209-0
Email: info@northcomp.com

www.northcomp.com